



E-street Initiative

WP3

Adaptive Street Lights

Tender documentation

Technical system

On behalf of the E-Street project (www.e-streetlight.com)



And supported by:



The sole responsibility for the content of this publication lies with the authors. It does not necessarily reflect the opinion of the European Communities. The European Commission is not responsible for any use that may be made of the information contained therein.

2007-07-31

Content

1. GENERAL

- 1.1 Introduction
- 1.2 Purpose
- 1.3 Guidelines for the reader
- 1.4 Definitions and abbreviations

2.SYSTEM DESIGN

- 2.1 Overall architecture
- 2.2 Roadside equipment
 - 2.2.1 Technical requirements
 - 2.2.2 Functional requirements
 - 2.2.3 Performance requirements
- 2.3 Power system
 - 2.3.1 Technical requirements
 - 2.3.2 Functional requirements
 - 2.3.3 Performance requirements
- 2.3 Local control system
 - 2.4.1 Technical requirements
 - 2.4.2 Functional requirements
 - 2.4.3 Performance requirements
- 2.5 Central supervisory control system
 - 2.5.1 Technical requirements
 - 2.5.2 Functional requirements
 - 2.5.3 Performance requirements
- 2.6 Communication system / network
 - 2.6.1 Technical requirements
 - 2.6.2 Functional requirements
 - 2.6.3 Performance requirements
- 2.7 Future expansion / integration
- 2.8 Data exchange with external systems

3. DESIGN PROCEDURE

- 3.1 Purpose
- 3.2 Project management requirements
 - 3.2.1 General
 - 3.2.2 Organisation
 - 3.2.3 Design procedure
 - 3.2.4 Project meetings
 - 3.2.5 Project inspections
 - 3.2.6 Site management
 - 3.2.7 Confidentiality
 - 3.2.8 Insurance

3.3 Quality Assurance and control requirements

3.3.1 General

3.3.2 Factory Acceptance Test (FAT)

3.3.3 Site Acceptance Test (SAT)

3.3.4 Operation Acceptance Test (OAT)

3.4 Installation requirements

3.4.1 General

3.4.2 Installation drawings

3.4.3 Labelling

3.4.4 Contractor's responsibilities

4. DOCUMENTATION REQUIREMENTS

4.1 General

4.2 Provision of documentation

4.3 System documentation

4.4 Technical system overview

4.5 Technical system description

4.6 User's Manual

4.7 Maintenance Manual

4.8 Installation Manual

4.9 Equipment Manual

4.10 Operational quick reference guides

4.11 Software documentation, system and subsystems

5. MAINTENANCE REQUIREMENTS

5.1 General

5.2 Objectives

5.3 Maintenance operation

5.4 Maintenance support

6. SPARES AND TEST EQUIPMENT

6.1 General

6.2 Spare part list

6.3 Testing and maintenance equipment

7. TRAINING REQUIREMENTS

7.1 General

7.2 Definition of courses

7.3 Training schedule

7.4 Training documents

7.5 Training course requirements

8. REFERENCES

1. GENERAL

It would be hardly possible to elaborate a universal form for the tender documentation, considering the specific conditions, the existing practices and possibilities in each country.

This document describes the technical requirements of an Adaptive Intelligent Street Lighting System with the following components:

- Lighting equipment (roadside equipment);
- Power supply system;
- Dynamic Adaptive street lighting remote control:
 - Central supervisory control system;
 - Local control system;
 - Sensors.
- Communication system/network.

The technical requirements and system functionality are given in general terms.

The legal and financial questions are not object of this tender documentation.

1.1. Introduction

The traditional implementation and organization of street lighting have no possibilities for improving and development any more.

The dynamic changes in economy, energy supplies and ecology on a national, European and world like scale require an adequate modernization of street lighting. However, this would be possible only with a quite new functional conception which in fact means adaptability of street lighting. Simultaneous ensuring of the conditions of safe traffic and decreasing the energy consumption and operational costs could be realized in conformity with the constantly changing parameters of the environment. In conformity with the 24 hours change of daylight, the highly changeable traffic, the variable meteorological conditions and some extreme situations on the roads, it will be a big improvement if the intensity of street lighting could be varied in a dynamic manner. Obviously for the realization of adaptive lighting will be necessary new technical devices and methods that are offered by technical progress.

“Adaptive Street lighting” is the new conception and technical solution for the control of the street lighting as an adaptive lighting system.

1.2. Purpose of the adaptive street lighting

- To create conditions for safe traffic of motor vehicles;
- To reduce transport problems;
- To reduce energy consumption (to avoid excessive illumination);
- To reduce light pollution (to prevent light dissipation beyond the illuminated road);
- To reduce operation costs;
- Environmental protection. To reduce noxious emissions (see Kyoto Protocol);
- To restrict the use of harmful substances;
- Better environmental light comfort;
- Longer lamps' life.

1.3. Guidelines to readers (General guidelines for the readers of this document).

The readers of this document in the tender phase are all companies offering a solution, and later the reader is the contractor who is building a system.

This document states the goals of the E-street Project and the ways of their implementation. It describes the system structure and the technical requirements towards its subsystems: roadside equipment, power system, local control system, central supervisory system and communication network.

The content and project requirements for the implementation of Adaptive street lighting: project management, quality assurance and installation requirements are given.

The contents and requirements with respect to the documentation, quality assurance of factory products, installation and operation works, as well as the respective inspection tests are described as well.

The system construction documentation which shall be presented is indicated, and practical guidance on the element base, installation and operation is given.

The requirements for spare part provision and training of system operation personnel are stated.

1.4. Definitions and abbreviations

The following definitions and abbreviations are used in this document:

Adaptive lighting – lighting the level of which is governed by current local circumstances, level of daylight, including traffic volume, weather conditions, traffic accidents and roadwork.

Remote control – the remote control and management of public lighting.

Intelligent ballast and communications – dimming the luminous flux of lamps, current and voltage measurement at each lamp point and a wattage calculation and feedback function for detecting imminent failures of individual light sources and any network failures.

Local control equipment or unit – equipment, placed in the luminaire or in the light pole.

Sub central control – equipment placed in the lighting central (distribution cabinet).

Central supervisory control system (central management system) – consists of communication channels to surrounding system and administration database.

Client service application for street lighting – shall handle receipt and follow-up of customers' messages about street lighting.

Abbreviations

CAD	Computer Aided Design
CSCS	Central Supervisory Control System
RSCS	Region Supervisory Control System
DB	Dimmable Electronic Ballast with power line modem
GUI	Graphical User Interface
IAAAC	Information Access and Analysis Administration Center
LCC	Life Cost Calculation
LM	Luminance Meter

LSC, BN	Lighting SubCentral, Bridge node
MB	Magnetic Ballast
PLC	Power Line Controller with power line modem
RSTOE	3 Phases, Neutral and Ground
SAT	Satellite Communication System
SCADA	Supervisory Control And Data Acquisition
SCS	Slipperiness Control System
TCC	Traffic Control Center
TM	Traffic Measurement
WMC	Weather Monitoring Central
WS	Weather Sensors
PC	Personal Computer
LAN	Local area networks

2. SYSTEM DESIGN

2.2. Overall architecture

Fig.1 presents the architecture of an “Adaptive Street Lighting System”. Five subsystems are defined depending on the functions to be performed:

- Roadside equipment
- Power system
- Local control system
- Central supervisory control system
- Communication system/network

The Roadside equipment includes lamps, luminaires, gears, light pools. It is described in detail in item 2.2.

The Power system consists of transformer stations, power cabinets and power lines. It is described in detail in item 2.3.

The Local control system can be considered in terms of function as composed of two levels:

- **Level One** includes:

Luminaires with dimmable electronic ballasts [DB] controlling high pressure sodium or metal-halide lamps with power line modem for communication or wireless communication.

Or

Power line controller (PLC) with power line modem controlling magnetic ballast and sensors (for the passed vehicles, luminance meter signals, weather conditions – presence of rain, snow or freezing). The same sensors could be directly connected to the LSC.

- **Level two** includes:

Substation (SubCentral) with local segment (network) controller **LSC**;

Local power line controller **PLC** (with power line carrier communication).

The features of **LSC** and **PLC**, and their functions are described in item 2.4. A new technology renders dimming possible at several levels with two way communication.

Central supervisory control system (CSCS)

The system should be web-based and the complete monitoring, programming and control should be achieved by web-site programs (the design and the access to the system may differ and should be adapted to the organizational needs and the defined functional and performance criteria). All the information is collected in a host server. The system and the visible sites or installations are protected by log-in usernames and passwords as well as password level limited actions. The features of **CSCS**, their functions and performance are described in item 2.5.

Communication system/network performs data exchange between the different subsystems of E-Street and data collection in the Central Supervisory Control System and in the Lighting Sub Central. **The** communication system/network is described in item 2.6.

The **street lighting control centre** receives information about traffic volume from the traffic centre.

The **organization of weather condition station** depends on the local possibilities, practice and conditions.

Sensor system

Adaptive street lighting is realized according to the following information:

- traffic volume measured on the illuminated streets (**TM**);
- precipitation – it is a local phenomenon and shall be detected locally in every weather section (**WMC**);
- luminance of road surface measured on the illuminated streets (**LM**);
- slipperiness (icing) is also a local phenomenon and can be detected by **SCS**;
- Fog – detected by visibility meters.

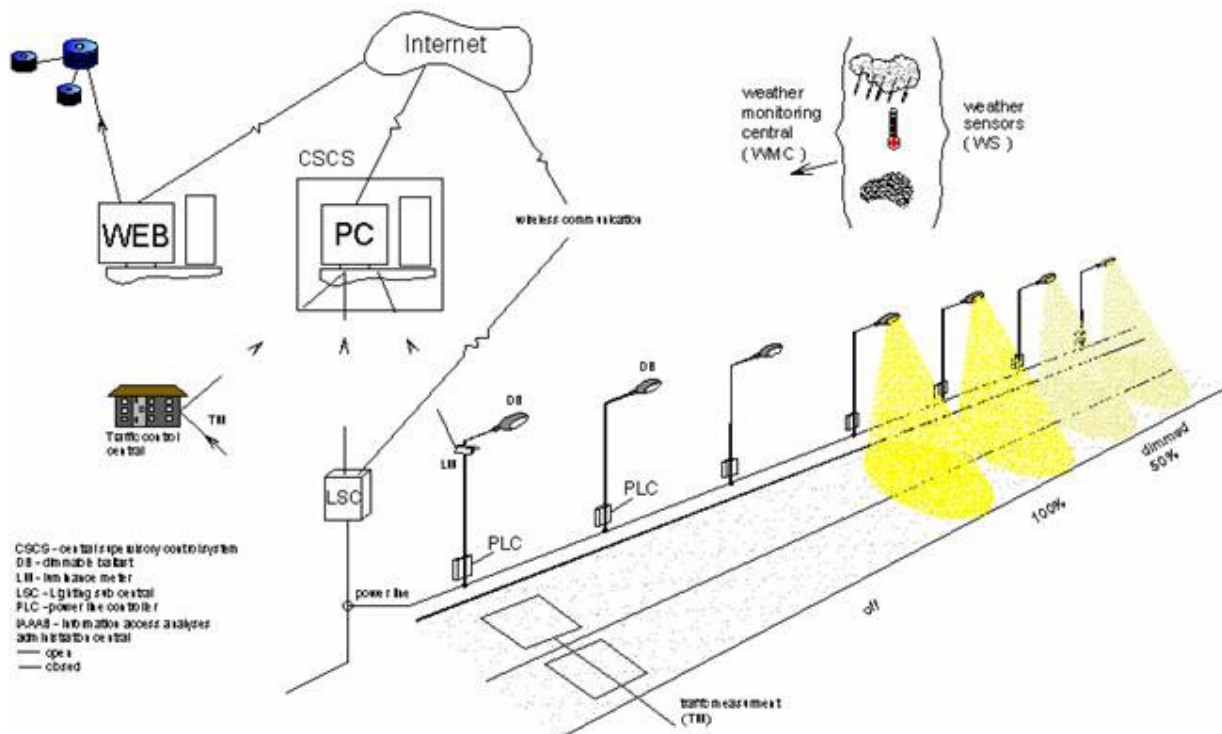

Fig.1. Overall architecture of the Monitoring System for Adaptive Street Lighting.

It is possible to integrate all PLC equipment and ballast in the luminaire as well.

2.3. Lighting equipment (roadside equipment).

The lighting installation can differ depending on the particular conditions, requirements and capabilities. To a large extent they are determined by the following two possible cases:

- Refurbishment of the existing street lighting installation;
- Construction of a new lighting installation.

2.2.1 Refurbishment of an existing street lighting installation is the most frequent case in practice. The tender document should include the following:

Input Data:

Geometry and lighting class of the illuminated streets; number and layout of luminaires, distance between luminaires, height of lamp poles and console outrigger arms size and type, road paving type, available traffic control and weather monitoring systems, situation of available transformer stations and power cabinets, routes and types of power supply cables, circuits and operating and protection devices in the distribution panels, existing control system, total installed electricity power and annual electricity consumption.

Technical, functional and performance requirements

- a. The street lighting installation equipment shall be designed in conformity with street lighting standards prevailing in each country (European or local street-lighting standards).
- b. The reconstructed lighting installation shall be energy efficient and environment friendly. This means that **the installed power of the lamps has to be as low as possible**. For this goal it is very important to choose a luminaire with suitable lighting distribution. This criterion shall be applied to the offer and will be of great importance when evaluating offers.
- c. Luminaires shall be equipped with control units, as has been specified in this document with reference to Adaptive intelligent lighting. Costs for luminaires shall be specified in the tender form along with all other components providing the Adaptive intelligent lighting functionality.
- d. Luminaires shall be constructed and tested according to EN-60 598.
- e. Luminaires and deliveries shall comply with current EU directives regarding outdoor luminaires. Luminaires and other products shall be CE-labeled.
- f. Luminaires placed in the same installation and with the same effect shall be of the same fabrication and type.
- g. The tender shall contain data sheets on all offered luminaires.
- h. The technical life expectancy on delivered luminaires shall be at least 20 years.
- i. Light sources shall be included in the delivery of luminaires. A high pressure sodium lamps shall have an expected service life at least 16 000 hours. It is possible to use all other types of lamps (HID and CFL). The light source shall be of the same kind as the one used in the illumination calculations supplied in the tender.

- j. Luminaire protection class (Dust and moisture protection) – IP 65 optical system, and IP54 electrical installation (see EN 60529) or IEC classification.
- k. Reflector optics made of anodized aluminum or with faceted surface with aluminum or silver covering.
- l. Luminaire body made of cast aluminum, polyurethane or fiberglass in conformity with the investor's possible requirements or determined by the Contractor.
- m. Protective glass or reflector made of thermally and shock-resistant glass or polycarbonate stabilized against UV radiation.
- n. The light source installation shall be able to meet safety requirements up to temperatures related to IEC 62035.
- o. Luminaires shall be clearly labelled information regarding what lamp type and lamp size the luminaire is designed for.
- p. The power cabinet shall meet all existing standards as of the date of their installation.
- q. Parameters of electronic ballasts should be: Supply Voltage: 180 - 260 Vac, 50Hz; Power factor: > 0.95; Ballast power: < 1W (lamp off); Lampe types: SON, Metal Halide (including CDM). Max ballast temperature: 75°C; Load current crest factor: < 1.1; Lamp power variation at +-15% supply voltage variation: 5%
With magnetic ballast a $\pm 10\%$ in line voltage variation causes a $\pm 20\%$ lamp power variation. If the power will be dimmed to a 70% power level, the light level will be 60%.
The electronic ballast feature should possibly justify a lower power set point (90%), while maintaining the same light level.
With electronic ballast dimmed power level to 60% and approx. – 50% light level.
- r. The luminaire components should contain no PCB or other harmful substances indicated in Directives 2002/96 EC and 2002/95 EC.
- s. Luminaire external design agreed upon with the street lighting owner, the Contractor and the municipal administration.
- t. Light intensity distribution of the luminaires should be in conformity with the light pollution requirements prevailing in the country.
- u. The design of luminaires should provide for easy maintenance, preferably without special tools.
- v. Requirements: a) For ballasts with radio communication interface; b) For ballasts with a DALI interface; c) For fitting with Lon Works-communication interface of the fitting.
- w. A master instruction manual should be prepared to render operation and maintenance of the fixture more efficient.

2.2.2. Although less frequently, some new lighting installations are built in newly built residential areas or overall renovation of the street lighting in the course of sanitation of old residential estates. The tender document shall contain:

Input Data

Street network layout, lighting class of the streets, type of pavement, available traffic control systems and meteorological conditions, existing power supply possibilities.

Technical, functional and performance requirements

- a. A rational layout (geometry) of the luminaires, lamp pole height and type, shape and dimensions of the overhangs shall be defined and proposed;
- b. The design solution shall be cost- and energy efficient. For that purpose, luminaires with appropriate light intensity distribution conform to optimal pole height should be chosen for the realization.

The other above-stated requirements for street lighting refurbishment are valid for a new lighting installation as well.

2.3 Power System

Technical, functional and performance requirements for lighting installation refurbishment

- 2.3.1 The power supply needs to be stable.
- 2.3.2 The rated voltage of the power supply network should be 230/400 V $\pm 5\%$, power supply system - RSTOE.
- 2.3.3. A substantiated design solution for location of the used street lighting transformers and power cabinets.
- 2.3.4. Design solution for the new geometry of the power supply network, cable type and cross-section.
- 2.3.5. Design solution for the distribution boards in the transformer stations and the power cabinets.
- 2.3.6. Coordination of the power supply network modifications with the power supply company and with the street lighting owner.
- 2.3.7. The Contractor shall inform the street lighting owner of the planned interruption of power supply and start of the construction works.

Technical, functional and performance requirements for new lighting installation

- 2.3.7. A substantiated design solution for number and location of the street lighting transformers and power cabinet.
- 2.3.8. The type of power supply network (cable or overhead) and the kind of cables/conductors shall be established.
- 2.3.9. The contractor shall propose a design solution for the distribution boards at the transformer stations and the power cabinets.

The other street lighting refurbishment requirements stated above apply to new lighting installations as well.

2.4. Local control system (PLC+LSC)

2.4.1. Technical and functional requirements to local PLC and to segment LSC controllers

PLC Local Controller

By means of a standard interface (**DALI** or alternative), the **PLC** connects (the lamp **DB**) to the segment controller **LSC** of the Adaptive lighting system. **PLC** should establish connection to **LSC** for:

- Automatic operation as a communication controller;
- **DB** testing;
- smooth dimming of the lamp luminous flux;
- on/off switching of the lamp;
- monitoring and data collection including:
 - lamp status (on/ off/, % dimming);
 - length of lamp operating time (by dimming levels);
 - number of lamp switching on and off;
 - -electrical parameters of the luminaire: supply voltage, lamp voltage and current (for approximate assessment of the level of emitted luminous flux, resp. End-of-Life protection, total power of the luminaire for assessment of losses in **DB**, resp., the rectify effect);
 - -Lamp and ballast failures also lamp near end of lifetime or broken lamp;
 - “Reset” of burning hours when lamp is replaced.

DB can be part of the **PLC** and accommodated inside its enclosure. In that case the combined startup-control apparatus (**DB+PLC**) is mounted inside the luminaire. When the luminaire has a double throttle (**MB**), the **PLC** is mounted in the pole base, and the luminaire is connected by the diagram shown in Fig.2.

Segment controller LSC

That is the main control of the local lighting installations developed to perform the following functions:

- to act as a router, setting a local area network (**LAN**) with/between local controllers **PLC**;
- to store information on the **PLC** lamp controllers operation over a definite time period (or number of commands, for example the last 100);
- To provide link (direct or through Internet) with control and monitoring devices external to the local system. Access is achieved in a wireless manner (by means of **GSM/GPRS/3G/IEEE802.11/IEEE802.16**) or through a cable line, depending on available means;
- The information exchanged with higher levels shall be protected against unauthorized access.

The PLC local controller shall have inbuilt functions for:

- configuration of the parameters followed by the local segment controller for changing the lamp operating data (such as parameter values as basis for alarm) and addition of off-normal operating mode messages (rectify +level, reduced luminous flux, lamp supplied but not lighting);
- automatic switch over to 100% operation mode upon failure of communication with the segment controller **LSC**;
- End-of-life operation programming feature.

The segment controller LSC shall provide road luminance level depending on:

- traffic volume: the roadway luminance levels in case of less busy traffic and reduced travel speed are coordinated with representatives of the traffic control system **TC**;
- weather conditions: in heavy rain the street lighting operates at 100% power mode irrespective of the traffic volume (according to information from **WMC**);
- Presence of fog: in the presence of fog the street lighting operates at 100% power mode irrespective of the traffic volume (according to information from a fog detection and determination system at **WMC**);
- Roadway icing: in presence of roadway icing the lighting installation operates at full (100%) power mode irrespective of the traffic volume (according to information from the **SCS** system at **WMC**);
- Road accidents or road repairs: in such cases the lighting system operates at 100% power mode irrespective of the traffic volume.

The segment controller LSC:

- should be able to provide photo switch or/and timer-aided control and dimming of the lighting installation by a real-time clock according to the annual calendar of sunrise and sunset (taking into account the street category) – in case of absence of communication with **CSCS (RSCS)**;
- Should be able to store an adequate volume of information (for one week minimum), transmitted from the lower system level (electrical parameters, times of lamp operation for different dimming levels, number of switching on and off, etc.);
- to inform **CSCS** of events related to parameters exceeding the set limits;
- to provide rough metering of power consumption by the lighting installation;
- to have an UPS assuring at least 3-hours operation after loss of supply (to preserve the information received from the local controllers **PLC**);
- to reduce the lamp power in order to contain the initially higher luminous flux within the limits of the required operating flux;
- to have hardware and software support (in lighting installation with electromagnetic ballasts) for the control of a voltage limiter for lamp dimming (Fig.3) matched to the mean operating value of the luminous flux and the actual supply voltage level, in order to prevent excessive power consumption in new lamps due to the maintenance factor (Factor of assurance).

2.4.2. Design of the local PLC and the segment (LSC) controllers

(It is also possible to use bi-level magnetic ballasts for dimming by switching the lamp power between 100% and 50%)

Fig.2 presents a typical design of PLC controller connected to the luminaire by means of bi-level magnetic ballast. By reduction of the current across the lamp (at low traffic) a mode of 50% luminous flux is obtained. The controller measures supply voltage, lamp current and voltage and calculates all parameters required for the data base – luminous flux level, losses in the ballast, rectify effect level of the lamp. By means of program-organized counters, the operation hours of the lamp for the two luminous flux levels are reported, as well as the number of switching on and off. One advantage of

the proposed circuit is that, upon loss of communication, the lamp operates at 100% of its power, directly through a normally-closed relay contact.

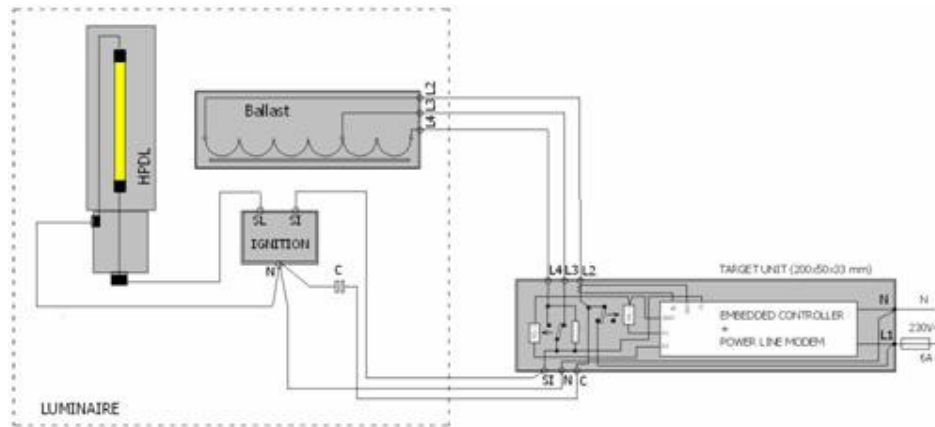

Fig.2. Local lighting installation (luminaire with ballast and target unit with PLM (luminaire controller))

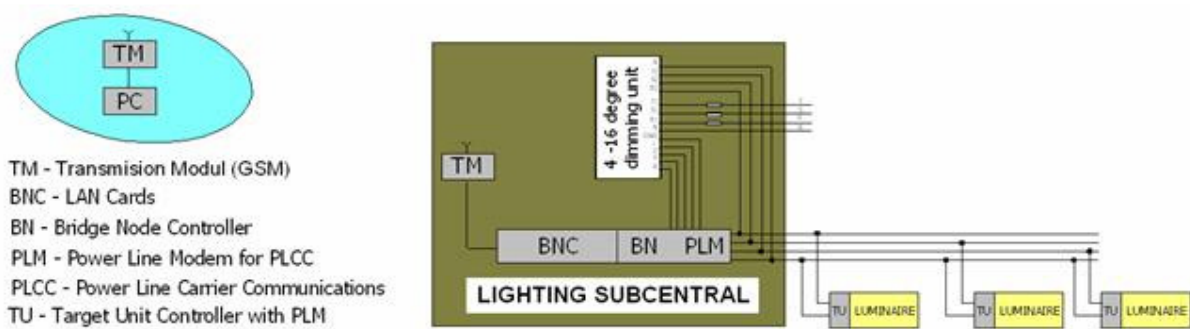

Fig.3. The Lighting SubCentral (section concentrator) and Section Power Supply Unit

Fig.3 presents a block diagram of LSC segment controller providing for the maintenance of a permanent light source flux irrespective of the design maintenance factor (factor of assurance). In that manner, extended service life of the light sources is assured as well as energy saving thanks to the operation at lower power. The use of a dimming device permits to set a limit to the high supply voltage levels and deeper 50% dimming at times of very low traffic.

2.5. Central supervisory control system (CSCS)

The higher level of the intelligent street lighting system consists of the Central Supervisory Control System (CSCS) and the Information Access and Analysis Administration Center (IAAAC);

The main CSCS center includes several regional RSCS (as required) local systems monitoring and control.

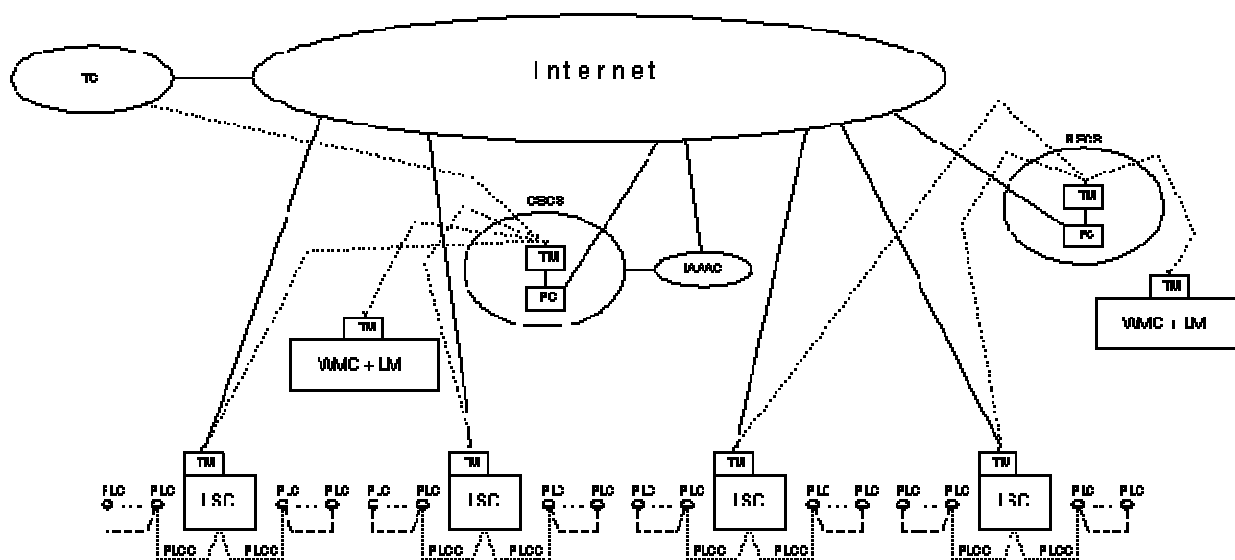

Fig.4. Information exchange in the Adaptive street lighting system

Communication with/between the **CSCS (RSCS)** – **TC** – **IAAAC** should be established through Internet with appropriate access authorization measures or with cable line. Besides, from a computer connected to Internet, it should be possible to observe the local systems (if system software has been installed). The Information Access and Analysis Administration Center should have the software support for issuing reports on the operation of the local systems. The addressee of the monthly reports, feedback channels and their incorporation in the operation documentation of the system shall be defined in advance.

2.5.1. Technical Requirements and Functions

The Traffic Control Center (**TCC**) is connected with a set of subsystems, one of which is the adaptive street lighting system (with one main **CSCS** and several regional **RSCS**). The Information Access and Analysis Administration Center **IAAAC** is a web-based management system using the data base at **CSCS (RSCS)** to provide operative information to the operating staff: hours of lamp operation, road accidents (time of occurrence and duration of remedial works), etc. The whole information from the segment controllers **LSCs** is stored in a **PC** acting as server. The computer is used to create a WEB-based data that can be used from a computer connected to Internet (taking the appropriate measures against unauthorized access). The computer at **CSCS (RSCS)** is able to connect to the **LSCs** (resp. **PLCs**) and visualize the information obtained from them.

It should be possible to establish two-way real-time communication between **PLCs and CSCS (RSCS)** and **CSCS** shall have possibilities to monitor the following things:

- Individual lamp status (burning hours, dimming level, electrical data etc.
- Alarms from lamp control units, communication failures at different levels

CSCS shall have report generators enables to extract the following things:

- Events, for example lamp operation data, e.g. on/off

- Burning hours, e.g. within a time period
- Alarm statistics during a certain time period

At CSCS the operator should be able to:

- Parameter handling, e.g. adjust, download and upload
- Manually control the system, segments and individual lamp, e.g. on/off

2.5.2. System software

The system software includes the following four functional modules:

- Configuration and installation performed by means of **GUI**. The configuration of each light point should be fully open. Programming shall not be limited at a level higher than that of an individual section and/or the power supply system.
- The operating module should be as simple as possible – on two displays. One of the displays is a work display used for communication, for example in the event of a road accident. The other display presents the status of a selected part of the lighting installation.
- Data collection module shall be affected by means of the **log** function recording reports and errors in the automatic system and storing them in the data base. Data collection is effected in the local and segment controllers. At regular intervals the data accumulated in the segment controllers is uploaded to the **CSCS** – at the dispatcher's (manager's) request or automatically, with an appropriate calendar function.
- Manager's package analyses based on an open structure of the data base: access to the main information in the data base and its analysis are carried out through an Information Access and Analysis Administration System (**IAAAC**).

2.6. Communication system / network

The communication system/network performs information exchange between the different subsystems of E-Street and collection of data in Central supervisory control system and in Lighting sub central.

The system should be in conformity with the two basic principles of efficient operation: reliability and easy operation. The data exchange between the local systems should be performed by means of wireless or power line communication. The local PLC controllers should be installed in the pole base The **PLC** design should permit easy installation / dismantling (preferably without any special tool).

There are two possible approaches to establish a communication link between the high-level elements of the system: 1) building of own Ethernet-type communication network; 2) use of networks for wireless two-way communication. In both cases there should be Internet connectivity. The choice depends on the owner's position and what is the coverage of the region by the mobile operator. Since normally wireless networks are performed in a way that voice traffic has priority than the data traffic, if wireless network is used, a priority for the data traffic should be considered and demanded from the mobile operator.

In the event of direct use of mobile networks for data exchange there will be no need for building of an own communication control system and of the street lighting. For that purpose, mobile networks of the following types should be used:

1) Second generation networks (2G – with digital transmission and with time or code multiplexing). The **GSM** standard developed for Europe (Global System for Mobile communications) is one of the most successful projects of ETSI (European Telecommunication Standards Institute), it is widely used - 70% of all mobile subscribers in the world operate in conformity with that standard, and guarantees coverage almost everywhere;

2) improved **2G** systems, known by the designation **2.5G** that feature at least one of the following technologies: HSCSD, GPRS, EDGE, offering solutions for higher-speed data transfer. It is preferable to use **GPRS** including services with generalized radio interface (General Packet Radio Services), where the customers share physical channels of the GSM network for data exchange in packets. That technology is offered by every mobile operator and is suitable for connectivity building;

3) third generation mobile networks (3G) provide much higher-speed data exchange compared to 2G and 2.5G, and access is implemented through code division CDMA (Code Division Multiple Access). 3G networks are well-known in Europe by the designation UMTS (Universal Mobile Telecommunications System);

4) IEEE 802.11 or IEEE 802.16 based wireless connectivity. WiFi (Wireless Fidelity) is a brand originally licensed by the WiFi Alliance to describe the embedded technology of wireless local area networks (WLAN) based on the IEEE 802.11 specifications. WiFi was developed to be used for mobile computing devices, but is now increasingly used for more services, including Internet access, and basic connectivity of consumer electronics. **WiMAX** (Worldwide Interoperability for Microwave Access) is defined as a technology by the **WiMAX** Forum, in order to promote conformance and interoperability of the [IEEE 802.16](#) standard, officially known as [WirelessMAN](#). **WiMAX** aims to provide wireless data over longer distances comparing to WiFi, in a variety of different ways, from point to point links to full mobile cellular type access, providing required quality of service guarantees. Both wireless technologies are developed for data transmission and therefore are suitable for the considered application.

All abovementioned wireless technologies are suitable for connectivity implementation (direct or through Internet) between the components of the Adaptive street lighting system and **PC** in **IAAAC** and **TC**.

All the access to each PLC should be performed through a central server (CSCS), meaning that any direct access to each sub-controller or lamp controller from Internet is impossible – the connection for monitoring and control through Internet is performed between the user and the central server.

For *monitoring* through Internet the communication channel does not have to be encrypted and should be established through the Internet standard protocols such as **TCP** (Transmission Control Protocol) and **UDP** (User Datagram Protocol).

In the case of *control* (between **IAAAC** and **CSCS** or **TC** and **CSCS**), an encrypted communication channel should be used for protection against unauthorized access. One

solution for secure data transmission is **VPN** (Virtual Private Network). A **VPN** is a private [communications network](#) used to communicate confidentially over a public network. **VPN** traffic can be carried over a public networking infrastructure (e.g. the Internet) on top of standard protocols (such as **TCP/IP**), or over a service provider's private network with a defined Service Level Agreement between the **VPN** customer and the **VPN** service provider. A **VPN** can send data across secured and encrypted private channels between two points. All access to each PLC's should go through a central server. This means that no user should have any direct access to each sub-controller or lamp-controller and that only the central server is able to access the individual node.

Technical, functional and performance requirements

Data transfer between the different units is as follows (Fig.4):

- Between the segment controller **LSC** and the **PLC** local controllers (optionally between **LSC** and **LM**) – over the supply lines using Power Line Modems (**PLM**) or wireless connection. The system used shall be approved by **CEN/CENELEC**;
- Between the segment controllers **LSC** and **CSCS** – directly or through Internet with access obtained through wireless **GSM/GPRS/3G/IEEE802.11/IEEE802.16** access or over a cable line.
- Between **CSCS** and **WMC**, **CSCS** and **TMC** (optionally between **CSCS** and **LM**) - direct communication established through wireless **GSM/GPRS/3G/IEEE802.11/IEEE802.16** access or over a cable line.
- Between **CSCS** and **TC**, **CSCS** and **IAAAC** - communication through Internet by wireless **GSM/GPRS/3G/IEEE802.11/IEEE802.16** access, or over a cable line. A **VPN** should be performed against unauthorized access.

2.7. Future expansion / integration

The system shall be adjusted for expansion and development over time. The supplier shall suggest a plan how this can be executed. The purchaser is allowed to state the demands that they have for future expansion and require from the supplier to describe the system flexibility in his offer. The built Adaptive lighting system should not be a “closed system” – it should be easily expanded

2.8. Data exchange with an external system

The Adaptive street lighting is a “living system”. It has permanent contact with other systems like: Traffic Management, Weather Sensor system, Central Lighting Application, etc. The efficient operation of E-street system is impossible without reliable contact to other systems.

3. DESIGN PROCEDURE

3.1. Purpose

The project procedures shall guarantee quality and reliability of the all system and its elements.

3.2. Project Management Requirements

3.2.1. General

The Contractor has the following very important obligations as:

- To monitor and control the project regarding performance of obligations defined in the timetable and all deliverables included in the Contract
- Responsibility for the administration of all aspects of the project including any subcontractor's duties and tasks.

3.2.2 Organization

The purchaser prepares a project's organization and the demands on the Tender/Contractor organization. The Tenderer must in his proposal to provide details of the internal management structure adopted for the completion of the project.

3.2.3 Project procedure

Each project includes different phases, which are described in the tender documentation: contract review, time table, preliminary design, technical (performance) phase, final project phase.

3.2.4 Project meetings

Contractor has to describe in the tender the contacts for reporting the project progress. In addition to regular formal contact with the Purchaser's Project Manager, the Contractor has to arrange monthly scheduled progress meetings with the Project Manager and client representative in order to enable monitoring of project timing. Such meetings shall be held during the period from commencement of the Contract to final commissioning of the project. In addition minutes of the progress meetings shall be written/recorded by the Contractor and copied to the Project Manager and client.

3.2.5 Project inspections

The Purchaser can use all forms of inspection: continuous, cycle, daily, compulsory, finished good inspection. The Project Manager and/or representatives of the Purchaser shall be entitled to make inspections of the Contractor's work areas in order to verify the progress of work. This right shall exist throughout the term of the Contract including the term of the subsequent maintenance and service schedule.

3.2.6 Site management

There are possible different forms of site management the previous agreement between the Purchaser and the Contractor. Normally the Contractor will not be provided with offices by the Purchaser. The Contractor is responsible and expected to establish any necessary facilities if needed on for example a land area agreed by the purchaser. These facilities shall house all equipment, materials, and tools necessary for the installation of the technical system and will be of temporary nature. The facilities should be removed upon completion of project and the site restored to its original condition. The

contractor is responsible for keeping this temporary area clean and clear of any safety hazards.

3.2.7 Confidentiality

The Contractor shall disclose no information whatever about the project to any third party without the express permission of the Purchaser.

3.2.8 Insurance

The Contractor shall be responsible for ensuring project including all materials and equipment (included and used) until completion.

3.3. Organization and Design Procedure

The owner of the future adaptive street lighting shall provide the contractor with the input data required for development of the respective designs. Besides, it shall describe specifically and precisely all technical, economic, energy and operating requirements, including design cost and time limits. The Contractor shall arrange for coordination of the designs with the other local technical facilities, with the electric power supplier, the municipal administration, the transport administration.

The designs shall be approved by the respective authorized institutions.

3.4. Quality Assurance and Control Requirements

3.4.1. Factory Acceptance Test (FAT)

The purpose of the FAT is to verify that the system meets all the demands specified in this document, as far as possible, when installed in a test environment.

FAT

Participants: Contractor, Purchaser

The system can be installed in the production environment after an approved FAT. If a FAT fails, additional FAT's shall be arranged until the system is approved by the purchaser.

The FAT of the installation shall be conducted in a laboratory environment before delivery to the purchaser.

The FAT shall be performed according to a FAT protocol.

This test protocol is a part of the contract and shall be delivered to the purchaser for review well before the actual FAT is planned to take place.

The FAT shall include tests of the communication with **CSCS** using the gateway provided by the purchaser

These tests shall be coordinated with the purchaser.

All functions and functional correlations shall be tested in such a manner that all the equipment in the functional chain is tested as whole. The tests shall include both operational and maintenance related functions.

All objects shall be tested for status, operational status, and exchange of messages, alarms and logging.

Stability and durability performance shall be verified.

The tests shall include normal as well as abnormal operational conditions.

The test shall at least include the following parts:

Inspection of:

- System description
- Technical documentation
- Installation manuals
- Source code
- Functional tests:
 - All the specified base functionality in the system shall be tested.

Communication with local installations shall be set up in order to verify that the demands on function and communications are met.

Performance tests:

The system is tested against specified performance requirements.

3.4.2. Site Acceptance Test (SAT)

The purpose of the SAT is to verify that the system meets all the demands specified in this document, as far as possible, when installed in the production environment (on-site).

SAT

Participants: Contractor, Purchaser,

Purchaser's representative from the control centre.

The system shall be tested after it is installed in its design environment (on-site). If a SAT fails, additional SAT's shall be arranged until the system is approved by the purchaser.

The SAT shall be performed according to a SAT protocol. This test protocol is a part of the contract and shall be delivered to the purchaser for review well before the actual SAT is planned to take place.

All specified functions between the local installation and the **CSCS** gateway shall be tested.

The test shall at least include the following parts:

Inspection of:

- System description
- Technical documentation
- Operator manuals
- Functional tests:
 - System functionality tested against **CSCS**
 - Integration in the purchaser IT environment is tested
- Performance tests:
 - The system is tested against specified performance requirements

The SAT can be divided into multiple stages allowing for new installations to be connected to the system when they are ready to be tested.

All parts of the system shall be complete at the time of roll-out.

If the contractor is unable to carry out certain test steps and procedures in the order proposed by the purchaser, the contractor shall notify the purchaser of this condition.

The tests shall include normal as well as abnormal operational conditions.

3.4.3. Stability test (OAT)

The behaviour and stability of the system shall be monitored during a certain period and during selected parts of the year (summer, winter, good weather conditions and poor weather conditions). The monitoring starts when all the installations in the system are connected and operational. This is done to ensure that no long-term errors arise. Suggestions on appropriate test periods and conditions shall be provided by the contractor in cooperation with the purchaser.

4. TECHNICAL DOCUMENTATION

4.1 General

General requirements on the documentation and delivery.

It is essential that documentation is of a high standard and that text is presented in a clear and correct language.

Where possible, diagrams, pictures, etc. must be used as supplement to the text.

The documentation shall:

- contain indexes and glossaries
- be written in x or English language
- Present information in a clear and logical manner
- provide cross-referencing between drawings, diagrams and text
- contain drawings using standard symbols
- match the equipment supplied to Purchaser

All documentation shall be a subject to the Project Manager approval.

Purchaser reserves the right to review and comment all draft versions of documentation.

All documentation must be delivered both in printed form and as computer readable files. Purchaser define formats.

4.2 Provision of documentation

Define all documentation items which shall be included in the delivery as for example:

- System documentation (overall architecture, technical requirements, functional requirements, performance requirements);
- Hardware documentation (technical requirements and functional requirements);
- Subsystem documentation (technical requirements, functional requirements and performance requirements);
- Software documentation;
- Maintenance, installation and equipment manuals.

4.3 System documentation

The documentation shall be worked out to give a full overview of the integration of the various subsystems. The documentation must be considered relevant by the Supplier and accepted by the Purchaser.

4.4 Technical system overview

Technical system overview gives an outline of the complete system as delivered and a general overview of the subsystems and outlines the structure of associated documentation. For the engineering staff it is described how the subsystems are composed and their functions.

4.5 Technical system description

It gives a broad outline of the complete relevant subsystems, an overview of hardware and software, and main technical data, their interfaces and outlines the structure of associated documentation. For the engineering staff it is described how the subsystems are composed and their functions.

4.6 User's manual

User's manual shall give a detailed description of all functions and how to operate the system, seen from the user's point of view.

4.7 Maintenance manual

Maintenance manual describes how to maintain the system in a preventive and corrective manner. The documentation includes functional block diagrams and fault tracing trees in order to support service personnel in their efforts.

4.8 Installation manual

The Installation Manual includes full details on the physical installation including drawings and diagrams for external connections and system's internal interconnection.

4.9 Equipment manual

The Equipment Manual gives full details of the subsystems or units on the following subjects as a minimum:

- General description
- Complete block/logical diagrams
- Mechanical and electrical data
- Interface data
- Configurations and parameter/switch settings

4.10 Operational quick reference guide

Extract of the User's manual to provide a quick reference to all functions accessible for an operator.

4.11 Software documentation, system and subsystems

All software documentation used by the Supplier to produce the complete software for all subsystems shall be delivered.

Software documentation must be accurate, up-to-date and easily maintainable. All source programs and listings must form part of the delivery.

The vendor must provide the source code of the software programs to the contractor if he withholds support of the built street lighting system.

5. MAINTENANCE REQUIREMENTS

The traditional maintenance system has a high consumption of person hours: inspecting the lamps, urgency, different faults to be determined, etc.

The “Adaptive street lighting” will decrease running and maintenance cost, contributing to better and faster service and reducing the person hours and maintenance expenses.

The vendor has to provide at least 2-years warranty and at least 10 years post-warranty service with additional contract.

6. SPARES AND TEST EQUIPMENT

The supplier must guarantee that the requested equipment/ backup equipment/ replacement fixtures can be delivered for at least 15 years post delivery. The time of delivery should be not longer than 30 days.

7. TRAINING DESIGN AND IMPLEMENTATION

One of the main obligations of the contractor will be to train the staff of the purchaser’s organization to operate the system using the delivered documentation.

7.1. General

The training should be organized according to the following 4 stages scenario:

Training needs analysis (TNA)

The analysis of the knowledge, skills and competences of the staff in the purchaser’s organization is significant in order to evaluate their basic knowledge and capability to understand technical documentation and to perform proper maintenance and service activities with all the delivered equipment for efficient operation and managing of the systems.

Training programme design

A training programme will be designed to meet the specific needs of the purchaser’s organization. The structure, contents and length of the training activities offered will depend on the results of the TNA at the purchaser’s organization. All operation

instructions, technical and training documentation as well as rules for health and safety instructions will be included in the programme.

Training implementation

Training will be organized and delivered by the contractor after the training proposal is accepted by the purchaser. The system supplier will train the technical manager, road traffic manager and all the other managers at the purchaser's organization to become familiar with the operating of the system up to light point level.

Training evaluation

Training sessions will be finished with a written test. A questionnaire will be prepared for obtaining the trainee's opinion about the training methods used and the trainers' presentations.

7.2. Definition of courses

The training shall be held before the installation is operational and will cover design, functions, adjusting, tuning of the system and its maintenance.

The contents of training will obligatorily include the five subsystems of the main system offered:

- Roadside equipment
- Power system
- Local control system
- Central supervisory control system
- Communication system/network

7.3. Training schedule

The training shall cover the different functional scenarios and service of the equipment delivered under the contract in different areas such as:

- Configuration – Configuring components; database updating and management.
- Operation – Increasing illumination level in the event of an accident; using the operational module
- Logging – Using the management module.
- Analysis: information retrieval and analysis (corrective and preventive).

7.4. Training documents

At the end of the training programme all trainees will go through a written test in order to prove that the skills and knowledge taught are well mastered.

Certificates will be issued to the participants who have successfully passed the training programme.

7.5. Training course requirements

Training shall be delivered with respect to the following requirements:

- Approval. Training programme will be designed on the basis of the TNA results and approved by the purchaser before the training starts;
- Classroom training. Training will be organized off-the-job in training rooms equipped with all the necessary facilities for effective training – multimedia, computer, flipchart, screen, trainer’s power point presentations;
- Handouts. Trainees will receive copies of the trainers’ power point presentations and/or the documentation discussed;
- Trainers. Trainers should be well qualified, understanding perfectly well the technical documentation offered as well as the methods of interactive training of adults
- Evaluation. Training ends in a written test including questions from the approved training programme;
- Certification. Certificates will be issued and delivered to all trainees who have successfully passed the training programme.

8. REFERENCES

Directives 2002/96 EC and 2002/95 EC - Harmful substances.

EN 13201 – Road lighting

EN 60598-1 and EN 60598-2 – Luminaires General Requirements

EN 60188 – High pressure mercury lamps

EN 61167 – Metal-halide lamps

EN 62035 – Discharge lamps – Safety requirements

EN 61347-2-9 – Lamp control gear for discharge lamps

CIE 154:2003 The maintenance of outdoor lighting systems

ANSI/EIA 709.1 protocol

IEEE 802.11 Standard

[IEEE 802.16](#) Standard

TCP/IP, OSI models

EN 60529

Legal issues as follows:

- The purchaser should have full rights to use all information produced within the project as drawings, documents etc. in his own business, e.g. change it according to own purposes.
- The purchaser shall be provided with software packages and instructions so he is able to reinstall software if necessary, e.g. in case of failure
- The right to the construction and source code has to be regulated according to how much the purchaser has been involved in the development. In case of buying a “turn key” construction normally the essential parts, like source code could be placed at a third party, e.g. commercial chambers, according to a defined contract. This probably differs within different countries.